

ATTACH (4) 10' 2x3 FOR THE LEGS WHILE FRAME IS ON IT'S SIDE

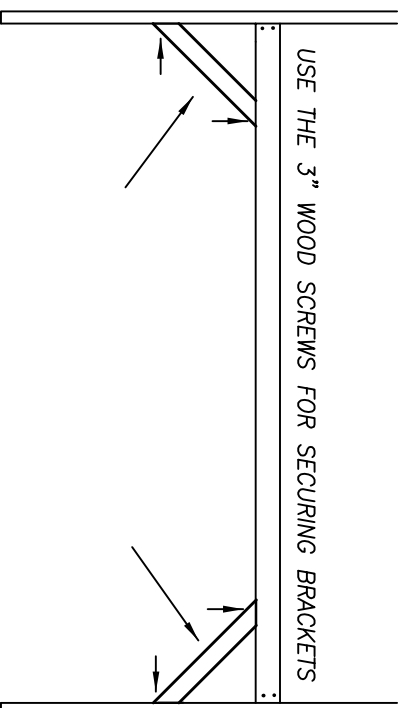

MEASURE INSIDE THE LEGS AND ADD 2X3 BRACKETS
CUT (4) PARALLEL AT 45°

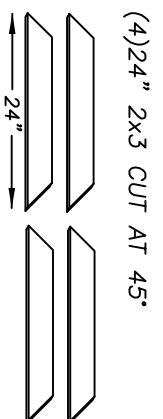
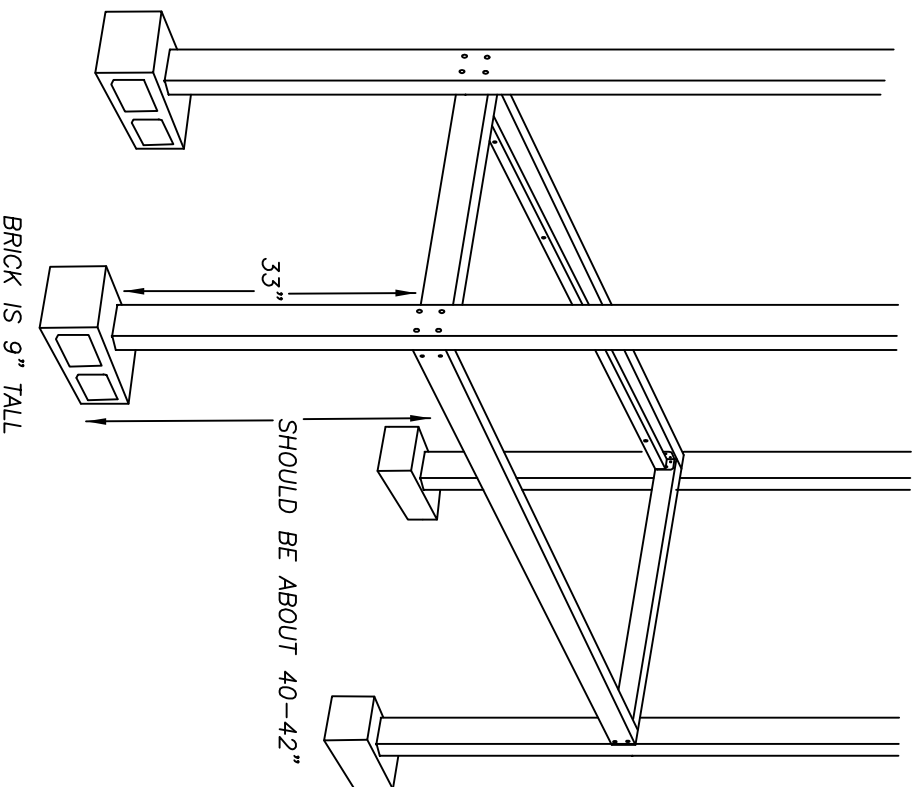
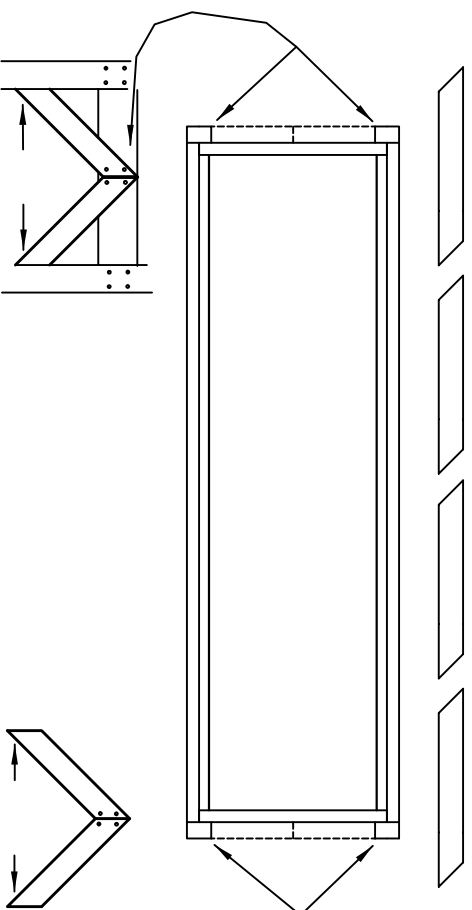

THIS IS YOUR LAST CHANCE TO GET LEVEL!!!